

Hermetic interconnect solutions

JULUS

Hermetic Industrial Feedthrough Connectors



martec[®]
an Amphenol[®] company

Perfect Connections for Mission Critical Applications

www.martec.solutions

Who we are and what we do

Perfect connections for mission-critical applications

Our connectors and penetrators are the **ideal hermetic solution** for both power and data.

Martec products represent the very forefront of technology for applications where performance, quality and reliability are needed most.

Since 1987, we have designed and manufactured high-quality precision components from our world-class, purpose-built manufacturing site in Whitstable, UK.

Acquired by the Amphenol Corporation in March 2016, Martec continues with the additional security, financial support and backing of a highly recognised and successful global interconnect organisation.

Martec has become Amphenol's global centre of **excellence for the design, development and manufacture of hermetics and glass-to-metal seals**, with many years of experience with exotic materials and harsh environments where high pressures and temperatures put our products to the test.



With the combined expertise of a stable workforce, a programme of continuous investment and a forward-thinking environmental policy, **Martec has the vision, strength and resources** to meet and exceed customer expectations today and long into the future.

Testament to our reputation as a trusted business is Martec's first ever customer, from 1987, still being a client today, an impressive 37 years after their first order.



Providing solutions for harsh environment, high pressure and high temperature applications.

A culture of interactive innovation

We ensure that our products continue to challenge the norm when it comes to innovation by initiating regular product development lifecycles. This allows us to update our connectors and penetrators and apply our [latest research and development](#) to our range.

We can apply continuous innovation to our customers' solutions, even when requirements vary between conceptualisation and acceptance. We apply this mindset to existing products as well as one-off custom products developed for specific use cases.

Our experience has taught us that successful engineering projects result from clearly defined objectives, effective implementation and strong attention to detail.



Quality is at the absolute forefront of everything we do at Martec.

Our Project Development Objectives

1. Concept

Whether using standard or custom products, we will work closely with you to develop the right solution.

2. Initial development

We will work with you to create several working prototypes that meet all of the criteria specific to your project.

3. Full development

After reviewing the prototype options, we will develop the most effective into a fully functional product.

4. Qualification, testing and verification

We can support the qualification process through testing and acceptance test reports.

5. Pre-production

After our in-depth qualification phase, we will review all of our findings and support your product readiness reviews.

6. Production

Our expert manufacturing team will manage the entire production process with vigilance.

7. Obsolescence management

We will help to manage obsolescence by ensuring alternative solutions remain fit for purpose.

Julius Range Industrial Feedthroughs

Martec presents the Julius Range, a collection of high-performance hermetic connectors designed and manufactured exclusively for demanding applications where integrity is crucial.

Our Julius industrial feedthrough connectors bring reliability and performance to electronic systems throughout the military, aerospace and industrial sectors.

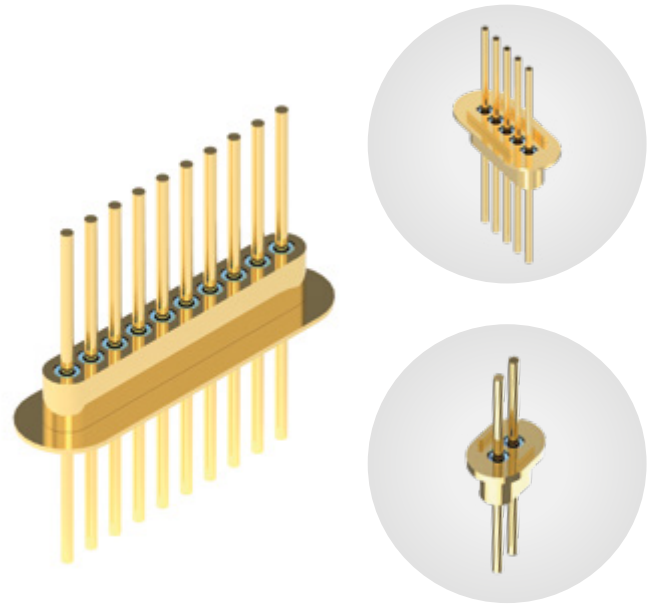

Key Features

- High-density pin count for high-performance applications
- Superior hermetic sealing ensures complete component protection
- High-pressure tolerance for extreme air and sea environments
- High conductivity and low resistance enable high-capacity transfer
- Wide temperature operating range with functionality up to 250°C.
- Max temp of 250°C. Min temp of -55°C

Key features of our hermetic feedthroughs include micro headers, which simplify assembly and withstand the stresses of harsh environments. We've also made soldering easy and accessible, with PCB stand-offs. These features come as standard across our Julius range, making our hermetic connectors some of the most reliable and dependable in the world.

Contact our factory for further information
Tel: +44 (0)1227 287 781
Email: sales@martec.ltd.uk

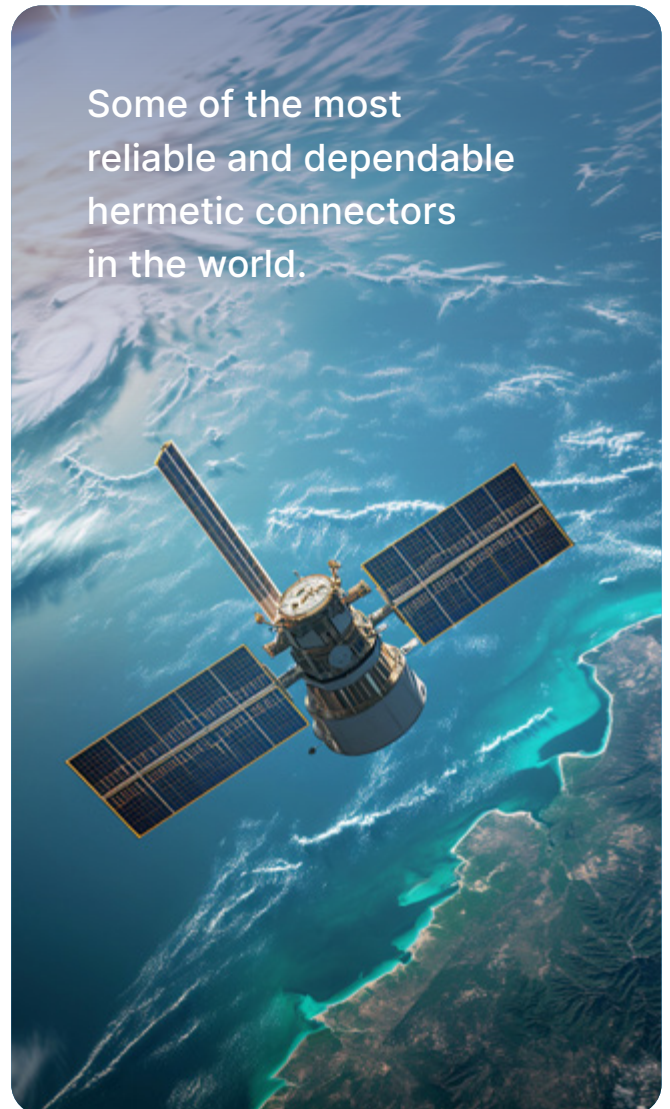

Technical Specifications

- Material: Stainless steel 316L
- Insulation: Glass
- Contact material: Alloy 52
- Standard plating: Sulphamate nickel plate per ASTM B689, type I (5 – 10 µm)
Finish: Soft gold plate per ASTM B488, type III (1.27 µm)
- Leak rate: $<1 \times 10^{-8}$ cc/sec @ 1atm (He)
- Maximum temperature: 250°C
- Insulation resistance: 1GΩ @ ambient
- Dielectric withstanding voltage (DWV):
*see breakdown rating table
- Features a PCB Stand-off



A must-have for any high-demand environment where a reliable, high-performing connector is key.

Standard Part Number Selection

Product Range	Series	L ₁ ±0.005 ^[1]	L ₂ ±0.005 ^[1]	No. of Pins ^[2]	Pin Type ^[3]
Julius - MSH series	A	XXX	XXX	XP	X
	B	XXX	XXX	XP	X
	C	XXX	XXX	XP	X
	D	XXX	XXX	XP	X
	E	XXX	XXX	XP	X
	F	XXX	XXX	XP	X
	Y	Call to discuss requirements			

Example Part No: MSHA-080-200-5P2

NOTES

- [1] L₁ & L₂ pin lengths in thousandths, .250 max. (0.050 increments).
- [2] 2 – 10 pins available on each series, contact Martec for specifications if more pins are required.
- [3] There are 4 pin types, differentiated by diameter: .018 (Type 1), .020 (Type 2), .025 (Type 3) & .030 (Type 4).

Technical drawings

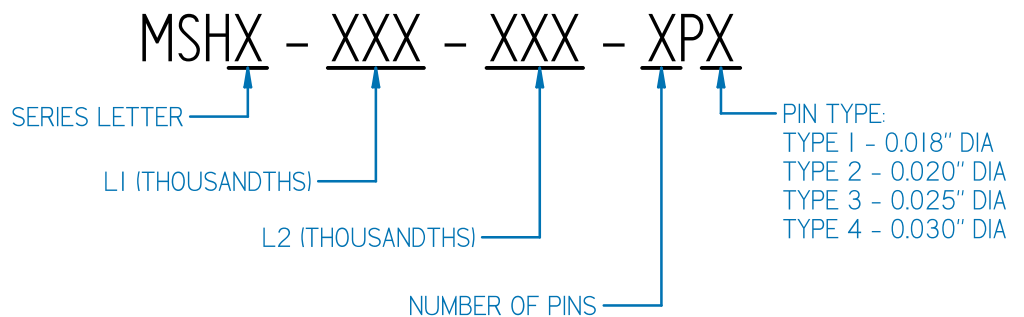
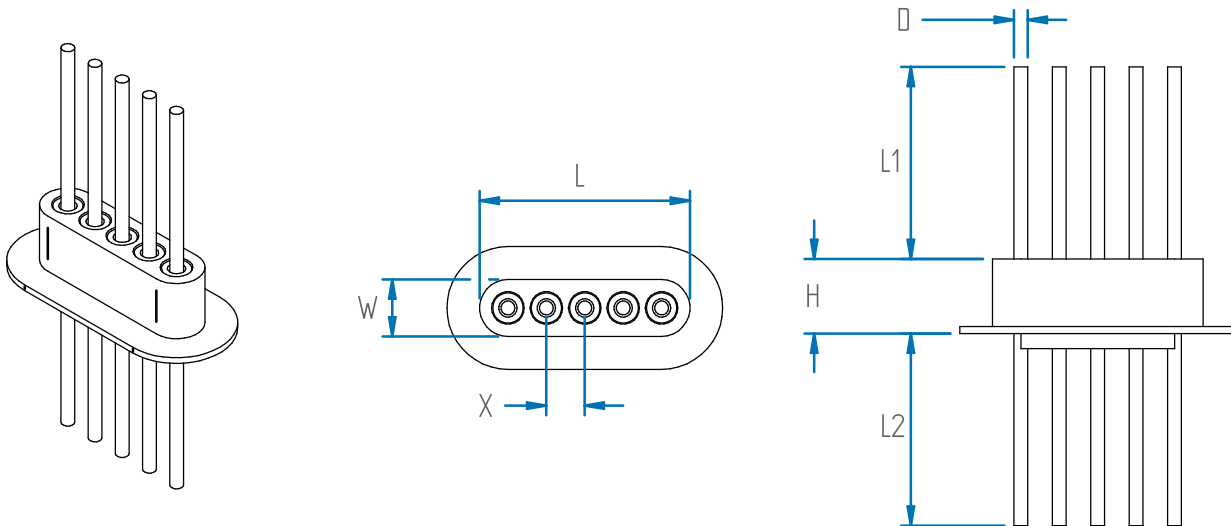

Specification

Shell Material	Stainless Steel 316L
Pin Material	Alloy 52
Standard Plating (Shell & Pins) ^[1]	Sulphamate Nickel plate per ASTM B689, Type I (5 – 10 µm) Soft Gold plate per ASTM B488, Type III (1.27 µm)
Leak Rate	1 × 10 ⁻⁸ cc/sec, 1 atm, in ambient conditions
Maximum Temperature	250 °C
Insulation Resistance	> 1 GΩ in ambient conditions
Breakdown	See table for breakdown values

NOTES [1] For different plating finishes, contact Martec to discuss requirements.

Breakdown Ratings (V)

	Pin Diameter (D)			
	.018	.020	.025	.030
Series A	250 V	250 V	-	-
Series B	500 V	400 V	400 V	-
Series C	600 V	600 V	500 V	500 V
Series D	600 V	600 V	500 V	500 V
Series E	700 V	700 V	600 V	500 V
Series F	800 V	800 V	700 V	700 V
Series Y	500 V	500 V	500 V	400 V

Basic Dimensions Series A

		No. of Pins								
		2	3	4	5	6	7	8	9	10
Series A	L	.124	.174	.224	.274	.324	.374	.424	.474	.524
	W	.074 ± 0.002								
	H	.097 ± 0.002								
	D	.018, .020 ± 0.001								
	X	.050 ± 0.003								
	L ₁ / L ₂	.XXX ± 0.005 [.250 MAX]								

Basic Dimensions Series B

		No. of Pins								
		2	3	4	5	6	7	8	9	10
Series B	L	.147	.207	.267	.327	.387	.447	.507	.567	.627
	W	.087 ± 0.002								
	H	.120 ± 0.002								
	D	.018, .020, .025 ± 0.001								
	X	.060 ± 0.003								
	L ₁ / L ₂	.XXX ± 0.005 [.250 MAX]								

Series C

		No. of Pins								
		2	3	4	5	6	7	8	9	10
Series C	L	.167	.247	.327	.407	.487	.567	.647	.727	.807
	W	.087 ± 0.002								
	H	0.120 ± 0.002								
	D	.018, .020, .025, .030 ± 0.001								
	X	.07874 ± 0.003								
	L ₁ / L ₂	.XXX ± 0.005 [.250 MAX]								

Series D

		No. of Pins								
		2	3	4	5	6	7	8	9	10
Series D	L	.167	.247	.327	.407	.487	.567	.647	.727	.807
	W	.087 ± 0.002								
	H	.120 ± 0.002								
	D	.018, .020, .025, .030 ± 0.001								
	X	.080 ± 0.003								
	L ₁ / L ₂	.XXX ± 0.005 [.250 MAX]								

Basic Dimensions Series E

		No. of Pins								
		2	3	4	5	6	7	8	9	10
Series E	L	.194	.294	.394	.494	.594	.694	.794	.894	.994
	W	.094 ± 0.002								
	H	.097 ± 0.002								
	D	.018, .020, .025, .030 ± 0.001								
	X	.100 ± 0.003								
	L ₁ / L ₂	.XXX ± 0.005 [.250 MAX]								

Series F

		No. of Pins								
		2	3	4	5	6	7	8	9	10
Series F	L	.228	.348	.468	.588	.708	.828	.948	1.068	1.188
	W	.107 ± 0.002								
	H	0.149 ± 0.002								
	D	.018, .020, .025, .030 ± 0.001								
	X	.120 ± 0.003								
	L ₁ / L ₂	.XXX ± 0.005 [.250 MAX]								

Series Y

		No. of Pins								
		2	3	4	5	6	7	8	9	10
Series Y	L	.200	.268	.336	.404	.472	.540	.608	.676	.744
	W	.107 ± 0.002								
	H	0.149 ± 0.002								
	D	.018, .020, .025, .030 ± 0.001								
	X	.115 / 0.092 / 0.068 ± 0.003								
	L ₁ / L ₂	.XXX ± 0.005 [.250 MAX]								

Basic Dimensions Illustrations

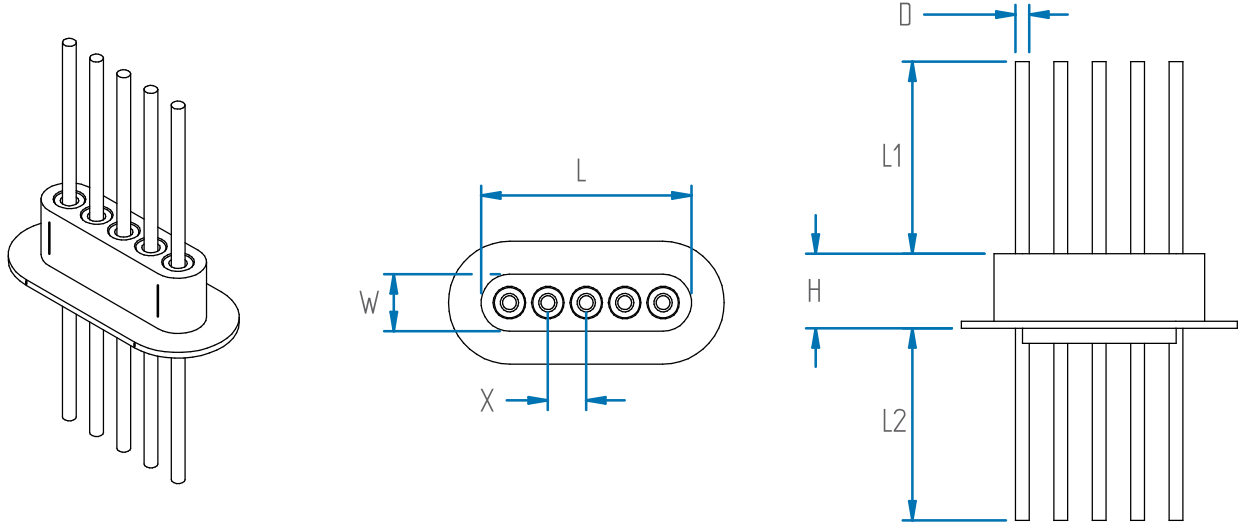

Application Data

		No. of Pins								
		2	3	4	5	6	7	8	9	10
Series A	A	.130	.180	.230	.280	.330	.380	.430	.480	.530
	B	.215	.265	.315	.365	.415	.465	.515	.565	.615

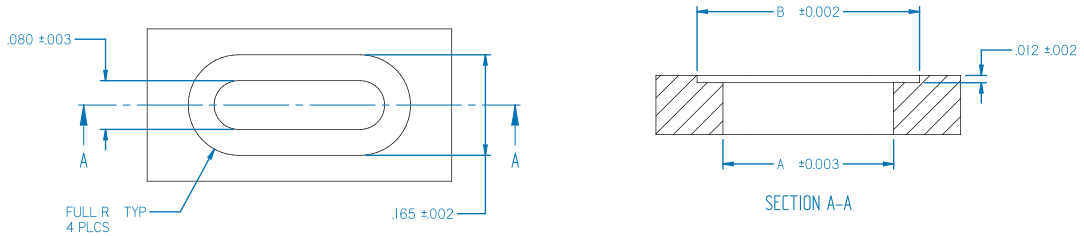

		No. of Pins								
		2	3	4	5	6	7	8	9	10
Series B	A	.153	.213	.273	.333	.393	.453	.513	.573	.633
	B	.215	.275	.335	.395	.455	.515	.575	.635	.695

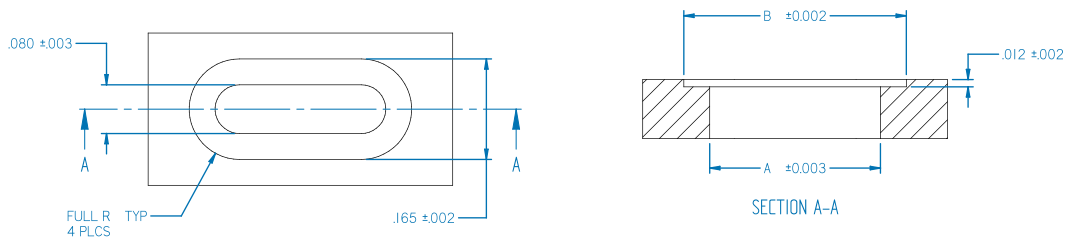

Application Data

		No. of Pins								
		2	3	4	5	6	7	8	9	10
Series C & D	A	.173	.253	.333	.413	.493	.573	.653	.733	.813
	B	.235	.315	.395	.475	.555	.635	.715	.795	.875

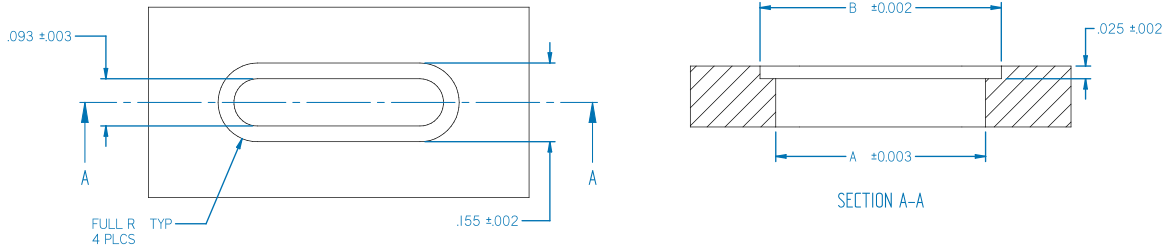

		No. of Pins								
		2	3	4	5	6	7	8	9	10
Series E	A	.200	.300	.400	.500	.600	.700	.800	.900	1.000
	B	.285	.385	.485	.585	.685	.785	.885	.985	1.085

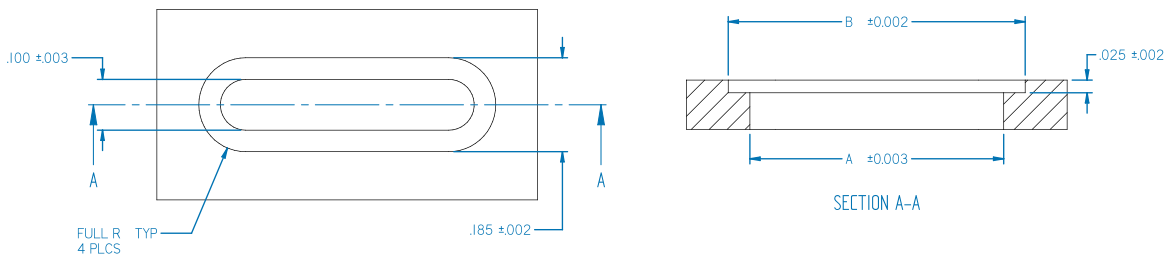

		No. of Pins								
		2	3	4	5	6	7	8	9	10
Series F	A	.234	.354	.474	.594	.714	.834	.954	1.074	1.194
	B	.295	.415	.535	.655	.775	.895	1.015	1.135	1.255

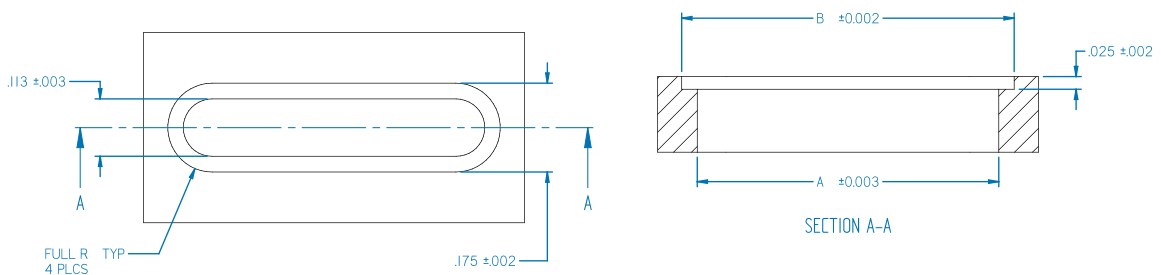



martec[®]
an Amphenol company

For more information call +44 (0)1227 287 781
or email sales@martec.ltd.uk

© 2024 Martec. Thanet Way, Whitstable, Kent, CT5 3JF

www.martec.solutions